

Removing and cleaning the floor head and roller brush

Before starting any cleaning, ensure the stick vac is not charging and is switched off and remove the floor nozzle from the rest of the stick vac.

If the roller brush becomes tangled during use, the self-protect system will shut off the stick vac. If that happens, please follow below steps.

1. Turn the floor brush head (I) upside down. To access the roller brush, slide the tab, marked with arrows, to the right.

2. Pull the roller brush at a slight angle up and out of the floor brush head. Any build up of hair etc. can now be removed from the roller brush. Scissors can be used to cut any hair away from the roller if necessary, taking care not to cut any of the brush bristles.

3. Once the roller brush is cleaned, replace the roller brush by aligning the left, open side of the roller with the star cog shape on the floor brush head. You may need to twist the roller head a little to lock this in place.

4. Push the other end of the roller down as far as it will go. Slide the tab back to the left to lock in place.

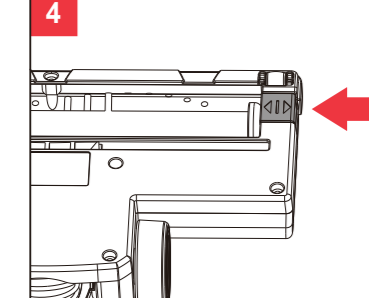
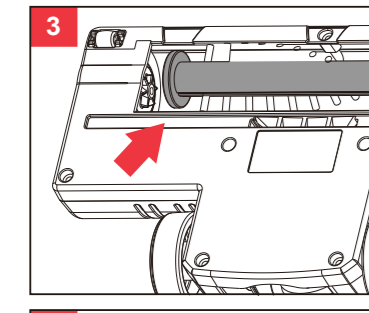
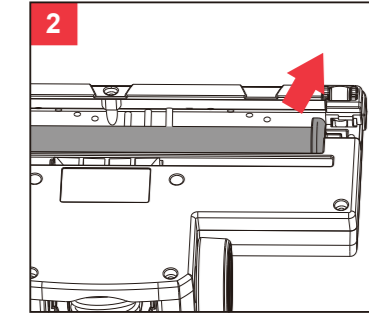
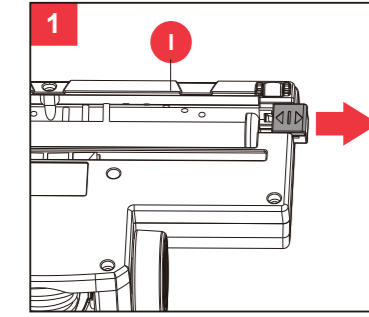

Clearing a blockage

Ensure the stick vac is not plugged into the mains supply and is switched off before dismantling the vac.

The stick vac would only become blocked if the dust cup has exceeded the 'Max' level, the filters are clogged up or a large object has been sucked up.

1. Check the dust cup and empty if necessary.
2. Check the 2 filters in the unit, remove any debris/dust and wash if necessary.
3. If the floor head, crevice or brush multi-tool were in use, detach them from the main body or extension pole and check for blockages. Remove any blockages.
4. Detach the extension pole and look down it to see if there are any blockages. If there are, use the handle of a broom to clear the obstruction. Take care not to damage the pole in the process.
5. Check the roller brush for any hair or thread which may have become wrapped around the roller. Cut away with a pair of scissors. To do this safely, remove as shown in the 'Removing and cleaning the floor head roller brush' section of this manual.

Storing the cordless stick vac

Your stick vac can be stored safely and securely by hanging from the wall mount supplied with your product or by removing all the attachments and stowing together in a cupboard. Either way will help avoid the product falling over and causing damage.

Always turn off and unplug from the mains supply before storing.

1. Remove any attachments if the stick vac was last used with them on.
2. Store the stick vac and accessories away safely in a dry place.

Storing the cordless stick vac with the wall mount

1. Find a suitable spot in your household where you'd like to secure your stick vac.
2. Mark the desired screw hole positions on the wall using a pencil. We recommend that the stick vac hangs slightly lifted off the floor.
3. Use the wall mount bracket fixings supplied only if suitable for your wall type.
4. Screw the wall mount bracket fixings and mount to the wall (see illustration for which way the mount should hang on the wall).
5. The stick vac can then be mounted on the wall mount. The mount hook can be found on the back on the main body near the handle.

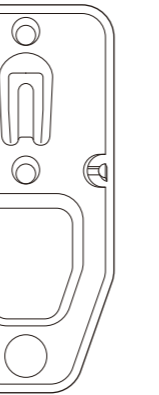

Troubleshooting

Problem	Solution
The stick vac is not cleaning well.	<ol style="list-style-type: none"> 1. Empty the dust cup 2. Remove excess dust from the filters 3. Wash the filters 4. Check for blockages
The stick vac has stopped or won't work.	<ol style="list-style-type: none"> 1. Charge the vac (check the mains socket works and the switch is turned on) 2. It might be blocked – check items 1 to 4 above 3. Product self-protection activated. Switch off the vac and leave the motor to cool for an hour then try using again.
The lights on the floor head turn off and/or the motor overheat light illuminates red.	<ol style="list-style-type: none"> 1. The floor head is blocked, refer to the 'Removing and cleaning the floor head and roller brush' section of this manual. 2. The roller brush motor has become overheated due to heavy loading. This might be due to extended use on a long pile carpet or loose rug. Leave the vac to cool for an hour then use the eco mode rather than the max mode.

Contact us

Helpline

If you are having a problem with your appliance, please call our Helpline, as we are more likely to be able to help than the store you purchased the item from.

Please have the product name, model number and serial number to hand when you call to help us deal with your enquiry quicker.

IRE Helpline: +353 1 8424833
Web: www.morphyrichards.com
Email: ServiceShared@glendimplex.com

Talk To Us

If you have any questions or comments, or want some great tips to help you get the most out of your products, join us online:

Blog: www.morphyrichards.co.uk/blog
Facebook: www.facebook.com/morphyrichardsuk
Twitter: www.twitter.com/loveyourmorphy
Website: www.morphyrichards.com

Notes

Registering your 2 year guarantee

Your standard one year guarantee is extended for an additional 12 months when you register the product within 28 days of purchase with Glen Dimplex. If you do not register the product with Glen Dimplex within 28 days, your product is guaranteed for 1 year. To validate your 2 year guarantee register with us online at: www.glendimplexireland.com/morphyrichards/2yearguaranteeregistration

Or call our customer registration line +353 1 8424833

N.B. Each qualifying product needs to be registered with Glen Dimplex individually.

Please note that the 2 year guarantee is only available in the UK and Ireland. Please refer to the one year guarantee for more information.

Your 1 year guarantee

To qualify for the one year guarantee, the appliance must have been used according to the instructions supplied.

It is important to retain the retailer's receipt as proof of purchase. Staple your receipt to this back cover for future reference.

Please quote the following information if the product develops a fault. These numbers can be found on the base of the product.

Model no. Serial no.
All Glen Dimplex products are individually tested before leaving the factory. In the unlikely event of any appliance proving to be faulty within 28 days of purchase, it should be returned to the place of purchase for it to be replaced.

If the fault develops after 28 days and within 12 months (2 years if registered) of original purchase, you should contact the Helpline number quoting Model number and Serial number on the product, or write to Glen Dimplex at the address shown.

You may be asked to return a copy of proof of purchase. Subject to the exclusions set out below (see Exclusions), the faulty appliance will then be repaired or replaced and dispatched usually within 7 working days of receipt.

If you suspect a fault, follow the simple checks detailed below before retrying the appliance or calling the helpline.

- Check the filters for blockages and clean.
- Check the tools / tubes for blockages.
- Check the plug is firmly in the socket.
- Check the socket is working by trying another appliance.
- Check the fuse in the plug.

IF YOU ARE HAVING A PROBLEM WITH ONE OF OUR PRODUCTS, CALL OUR HELPLINE:

EIRE: +353 1 8424833

Glen Dimplex Ireland
Airport Road
Cloghran
Co. Dublin

Helplines (office hours)
Tel +353 1 8424833
Email Serviceireland@glendimplex.com

- If the filters were blocked or another blockage was noted, leave the product switched 'off' for 60 minutes and retry switching on (as safety cut-out may have activated).
- If, for any reason, this item is replaced during the 2 year guarantee period, the guarantee on the new item will be calculated from original purchase date. Therefore it is vital to retain your original till receipt or invoice to indicate the date of initial purchase.
- This appliance is intended for domestic use only. Misuse or use for commercial or any other purpose will render the guarantee invalid.

Exclusions

Glen Dimplex shall not be liable to replace or repair the goods under the terms of the guarantee where:

1. The fault has been caused or is attributable to accidental use, misuse, negligent use or used contrary to the manufacturer's recommendations or where the fault has been caused by power surges or damage caused in transit.
 2. The appliance has been used on a voltage supply other than that stamped on the products.
 3. Repairs have been attempted by persons other than our service staff (or authorised dealer).
 4. The appliance has been used for hire purposes or non domestic use.
 5. The appliance is second hand.
 6. Glen Dimplex reserves the right not to carry out any type of servicing under the guarantee at its discretion.
 7. The guarantee excludes consumables such as the bags and filters.
- This guarantee does not confer any rights other than those expressly set out above and does not cover any claims for consequential loss or damage. This guarantee is offered as an additional benefit and does not affect your statutory rights as a consumer. Glen Dimplex products are intended for household use only. See usage limitations within the location safety instructions.

Disclaimer

Glen Dimplex has a policy of continuous improvement in product quality and design. The company, therefore reserves the right to change the specification of its models at any time.

For electrical products sold within the European Community. At the end of the electrical products useful life, it should not be disposed of with household waste. Please recycle where facilities exist. Check with your Local Authority or retailer for recycling advice in your country.

EIRE: +353 1 8424833

morphyrichards

Helplines (office hours)
Tel +353 1 8424833
Email Serviceireland@glendimplex.com



morphyrichards
smart ideas for your home



Upright Cordless Vacuum Cleaner – Model No 980583

Please read and keep these instructions for future use

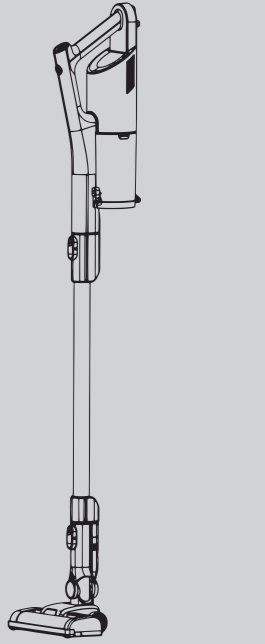

Contact us

Helpline

If you are having a problem with your appliance, please call our Helpline, as we are more likely to be able to help than the store you purchased the item from. Please have the product name, model number and serial number to hand when you call to help us deal with your enquiry quicker.

IRE Helpline: +353 1 8424833

For competitions, product hints and tips and more join us at

www.morphyrichards.co.uk/blog

www.facebook.com/morphyrichardsuk

@loveyourmorphy

www.morphyrichards.com

* Register online for your 2 year guarantee. See back of this instruction book for details. (UK and Ireland customers only)

Health and Safety

- Read this manual thoroughly before first use, even if you are familiar with this type of product.
- The safety precautions enclosed reduce the risk of fire, electric shock and injury when correctly adhered to.
- Keep the manual in a safe place for future reference, along with the completed warranty card, purchase receipt and carton.
- Always follow basic safety precautions and accident prevention measures when using an electrical appliance, including the following:
 - Before turning on, ensure the electrical voltage and frequency of the charging adaptor corresponds to those indicated on the rating label.
 - Do not leave the vacuum cleaner when plugged in.
 - Unplug from outlet when not in use and before cleaning or servicing.
 - Do not use outdoors or on wet surfaces.
 - Young children should be supervised to ensure they do not play with the appliance.
 - Do not insert any objects into the appliance.
 - Use only as described in this manual, use only manufacturers recommended attachments.
- Do not operate any appliance with a damaged charging adaptor or after the appliance damaged in any manner.
- Keep the charging adaptor and cords away from heated surfaces.
- Do not unplug by pulling on cord. To unplug, grasp the charging adaptor, not the cord.
- To reduce the risk of electrocution never operate the product with wet hands, submerge in water or spill liquids into the product.
- Do not use with any opening blocked; keep free of dust, lint, hair, and anything that may reduce airflow.
- Turn off all controls before unplugging.
- Do not use to vacuum flammable or combustible liquids, such as gasoline, matches, or use in areas where they may be present.
- Do not vacuum anything that is burning or smoking, such as cigarettes, matches, or hot ashes.
- Do not use without the filter in place.
- This appliance is intended for normal household use only.

- If the charging adaptor is damaged, it must be replaced by the same type.
- This appliance is not intended for use by persons (including children) with reduced physical, sensory or mental capabilities, or lack of experience and knowledge, unless they have been given supervision or instruction concerning use of the appliance by a person responsible for their safety.
- Children should be supervised to ensure that they do not play with the appliance.
- When charging the appliance, the power switch must be off.
- This Appliance should not be used by children or people who are physically challenged.
- This appliance is not a toy, and if not used in the correct manner, can lead to unnecessary damage or failure to perform.
- Battery type:** Li-ion 21.6V 2000mAh
- Do not recharge non-rechargeable batteries, the battery is not replaceable

Caution

- Do not use your appliance outdoors or on any wet surface or for wet pick up. Never use the product to suck up water.
- Do not pick up hard or sharp objects, matches, hot ashes, cigarette ends or other similar items.
- Do not spray with or pick up flammable liquids, cleaning fluids, aerosols or their vapours.

Product overview

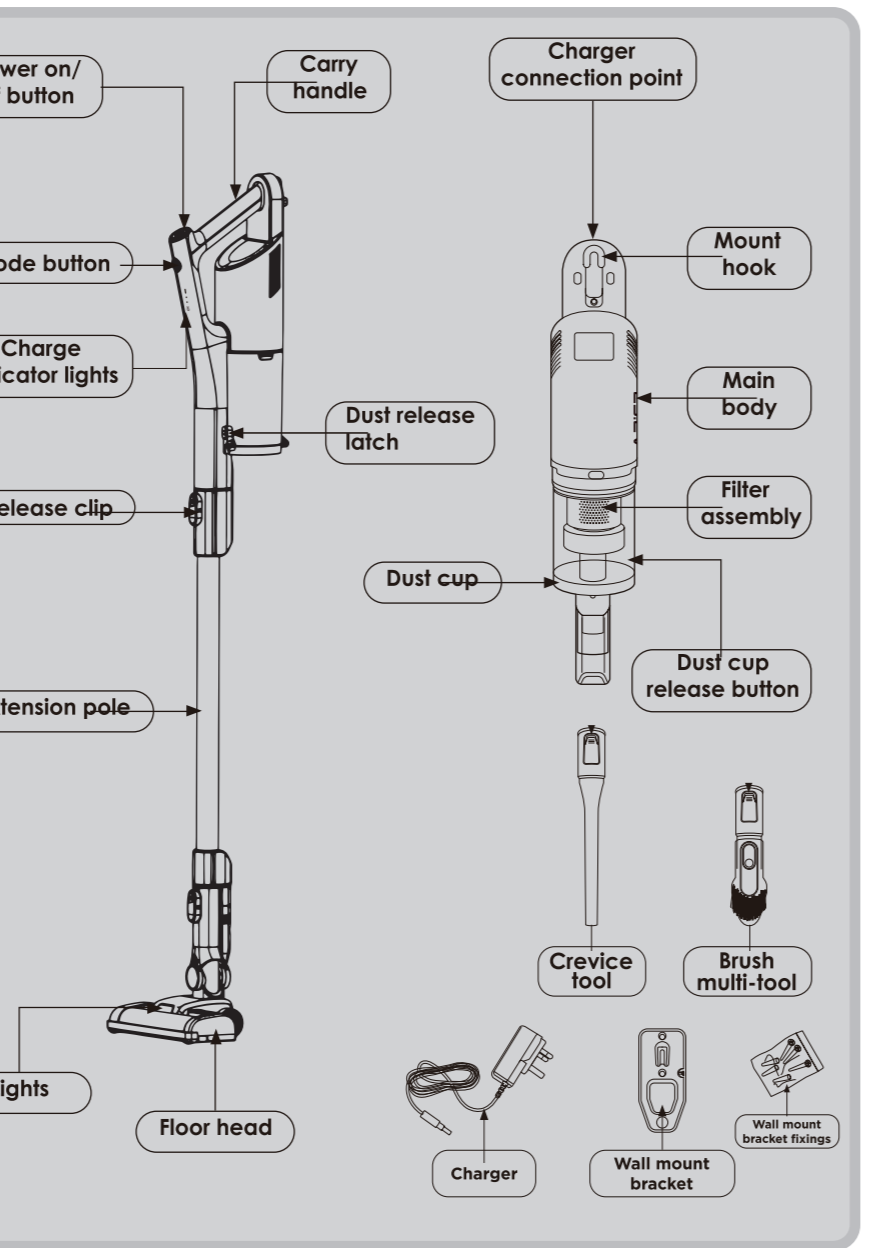

Product Operation

How to use your vacuum cleaner

Ensure the vacuum cleaner is fully charged and assembled before using. Always take care when vacuuming stairs.

- There are two power settings on the stick vac: max mode (this has a higher suction power but a shorter running time, approx 15 mins) and eco mode (lower suction power with a longer running time, approx 45 mins).
The stick vac will always start in max mode. The run time may vary depending on the surface being cleaned.
- For the 'max' mode simply press the power button (1), while for 'eco' mode press the power button (1) followed by the mode button (2). The max operation light will illuminate when in 'max' mode and go out when switched to 'eco' mode.

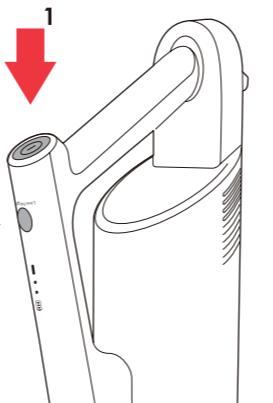

When required, press the power button again to turn off the stick vac.

- Move the floor head back and forth over the surface. Use even strokes. Don't press hard; allow the stick vac to suck away the debris. There are lights on the floor head which will illuminate automatically when the stick vac is in operation to help with visibility in dark corners/areas.
- The stick vac has charge indicator lights, these are the two small lights on the handle.
Whilst charging – the lower light will flash and the top light is off
Half charged – the lower light is on and the top light will flash
Fully charged – both lights are on, will turn off after 10mins
When in use and the battery is almost gone, the bottom light will be off and the top light will flash. After approximately 10 seconds the stick vac will automatically switch off.

- It is advisable to empty the dust cup after each use.

For best performance, check the filters are clean (see the 'Removing and cleaning the dust cup and filters' section of this manual).

Charging vacuum cleaner

Before use we recommend that the stick vac is charged fully for between 3 and 4 hours. When first purchased there will be some charge so it may not take the full amount of time to fully charge.

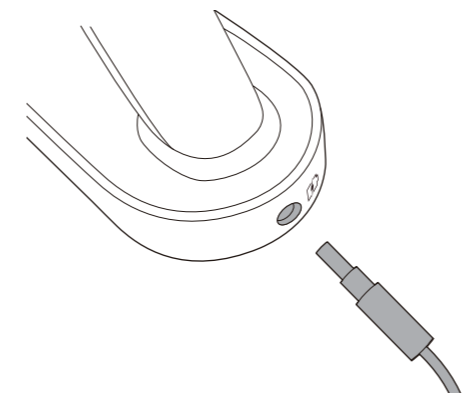

- Plug the end of the charger into the charger connection point located on the top of the stick vac main body. It is recommended that the stick vac is charged without any attachments connected and the appliance is laid on a flat surface.
- Plug the charger into the mains.

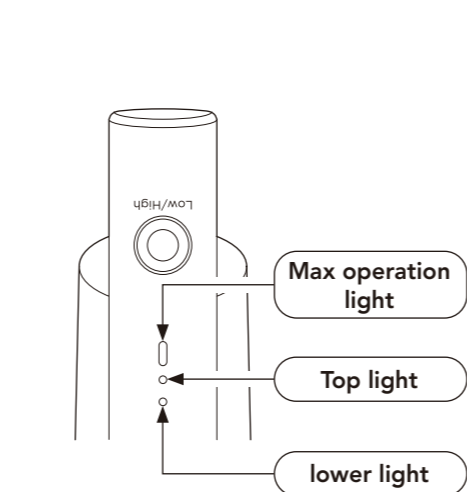

- Once fully charged, the charge indicator light will stop flashing and both lights will be lit.
- Turn off from the mains power and remove the charger.

Note: Do not leave the stick vac unattended or leave overnight when charging. The appliance will not work whilst charging.

Maintenance Guide

Emptying the dust cup

Ensure the stick vac is switched off and any attachments are removed before emptying the dust cup.

- Hold the cup assembly over a household bin and push the dust release latch on the side of the dust cup. The debris will fall out into the bin. Please note: Do not allow the dust cup to overflow. Don't exceed the MAX level marker. Empty regularly. Every time you empty the dust cup, check the filter assembly and tap gently over the household bin to remove any excess dust.
- Once empty close the lid until it clicks shut.

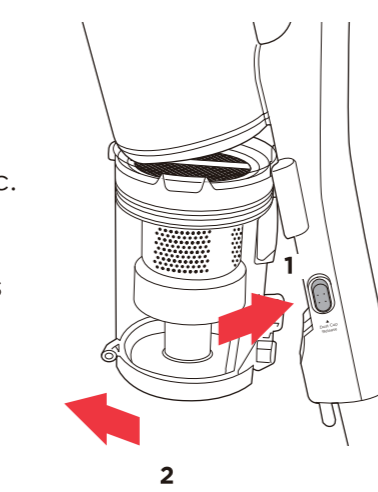
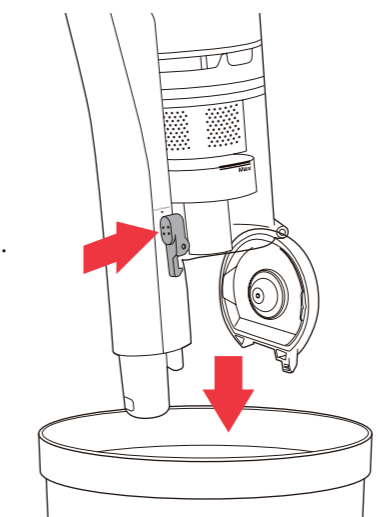

Removing and cleaning the dust cup and filters

Before starting any cleaning, ensure the stick vac is not charging and is switched off. It is easier to remove the dust cup without any attachments on the stick vac.

- Empty the dust cup as shown in the 'Emptying the dust cup' section of this manual.
- Press the dust cup release button located on the side of the main body near the bottom of the dust cup (1). Then pull the dust cup away from the main body, keeping the cup fairly upright (2).

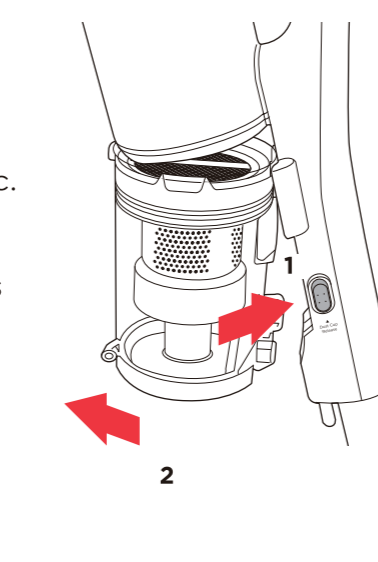

- The dust cup houses the circular sponge filter and filter assembly. Firstly remove the circular sponge filter by pinching the ribbon material at the top of the filter and pulling upwards, then set aside.
- Pinch either side of the filter assembly and pull upwards away from the dust cup. Tap the filter assembly gently over the household bin to remove any large amounts of dust.

Note: Do not allow the dust cup to overflow. Don't exceed the MAX level marker. Empty regularly.

- Remove any more excess dust from the filter assembly using a soft brush or a clean paint brush. The filter can be broken down into three parts. Hold the top section and twist the lower section in the direction of the arrow and the unlock padlock icon.

- Rinse the dust cup, filter assembly parts and circular sponge filter under warm water until the water runs clear and leave to dry for 24 hours.

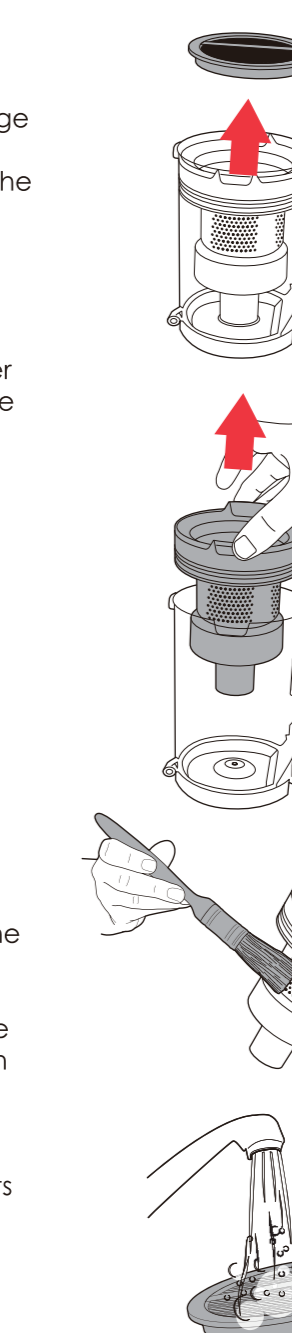

- Once all the parts are thoroughly dry, reassemble the filter assembly parts following the arrow and the icon for the locked padlock and place it back into the dust cup. Don't forget to put the circular sponge filter back in the top of the filter assembly.
- Replace the dust cup to the main body by hooking the channel on the top of the dust cup with the lug on the main body (1). Push the dust cup back towards the main body until you hear it click into place (2).

Note: It is important to regularly maintain and clean the filters. A clogged filter reduces suction power and can shorten the life of your stick vac.

Below is a recommended guide for how often you should clean the filters:

Filter type	Recommended cleaning times
Filter assembly	<ul style="list-style-type: none"> Shake out debris when you empty the dust cup. Use the soft dusting brush to gently remove any dust build-up. Rinse under warm water once a month or more often if required.
Circular sponge filter	<ul style="list-style-type: none"> Occasionally remove any dust/debris as necessary. The filter can also be rinsed under warm water once a month.

