

RN361000 MUK Rev3

**morphy richards**  
smart ideas for your home



\*Register at [www.morphyrichards.co.uk](http://www.morphyrichards.co.uk)  
UK customers only

## Garment Steamer

Please read and keep these instructions for future use

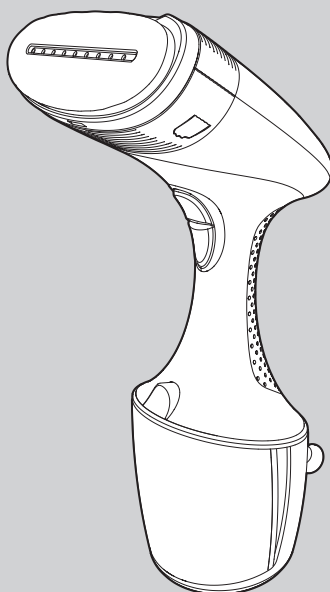

Register your guarantee online: [www.morphyrichards.co.uk](http://www.morphyrichards.co.uk)  
We'll keep you updated with special offers, competitions and important product information.

If you experience any problems with this Garment Steamer, do not return to the store.  
Please contact our help line who will be happy to help:  
[hello@morphyrichards.co.uk](mailto:hello@morphyrichards.co.uk)  
[www.morphyrichards.co.uk](http://www.morphyrichards.co.uk)



**IMPORTANT:** To reduce limescale damage we recommend using distilled, deionised or demineralised water only.

Never use battery topping up fluid or water containing any substances like starch, sugar, fragrant additives or defrosted water from a refrigerator.

Failure to maintain your Garment Steamer will invalidate your guarantee.

[www.morphyrichards.co.uk](http://www.morphyrichards.co.uk)

## Important safety instructions



- **WARNING: Care should be taken when using the appliance due to emission of steam.**

- **WARNING: Misuse of the appliance could cause personal injury.**
- This appliance can be used by children aged from 8 years and above and persons with reduced physical, sensory or mental capabilities or lack of experience or knowledge if they have been given supervision or instruction concerning use of the appliance in a safe way and understand the hazards involved.
- Children shall not play with the appliance.
- Cleaning and user maintenance shall not be made by children without supervision.
- Keep the Garment Steamer and its cord out of reach of children less than 8 years of age at all times.
- If the supply cable is damaged, it must be replaced by the manufacturer or its service agent in order to avoid a hazard.
- The Garment Steamer must not be left unattended while it is connected to the supply mains.
- The plug must be removed from the socket before filling the Garment Steamer with water.
- When placing the Garment Steamer on its base, ensure that the surface on which the base is placed is stable.
- The Garment Steamer is not to be used if it has been dropped, if there are visible signs of damage or it is leaking.



**CAUTION - HOT: Burns can occur from touching hot parts, hot water or steam.**

- **WARNING: To avoid electric shock, do not immerse appliance in water / liquid.**

### Electrical requirements and mains cable

- Check that the voltage on the rating plate of your appliance corresponds with your house electricity supply which must be A.C. (Alternating current).
- Do not operate with a damaged supply cord or grommet, it must be replaced by the manufacturer, its service agent or similarly qualified person in order to avoid a hazard.
- Do not let the mains lead come into contact with the hot hotplate of the Garment Steamer.
- Should the fuse in the mains plug require changing, replace it with a fuse of the same rating as originally fitted.
- **WARNING: This appliance must be earthed.**

**PLEASE READ ALL INSTRUCTIONS AND KEEP FOR REFERENCE**

## Garment Steamer overview

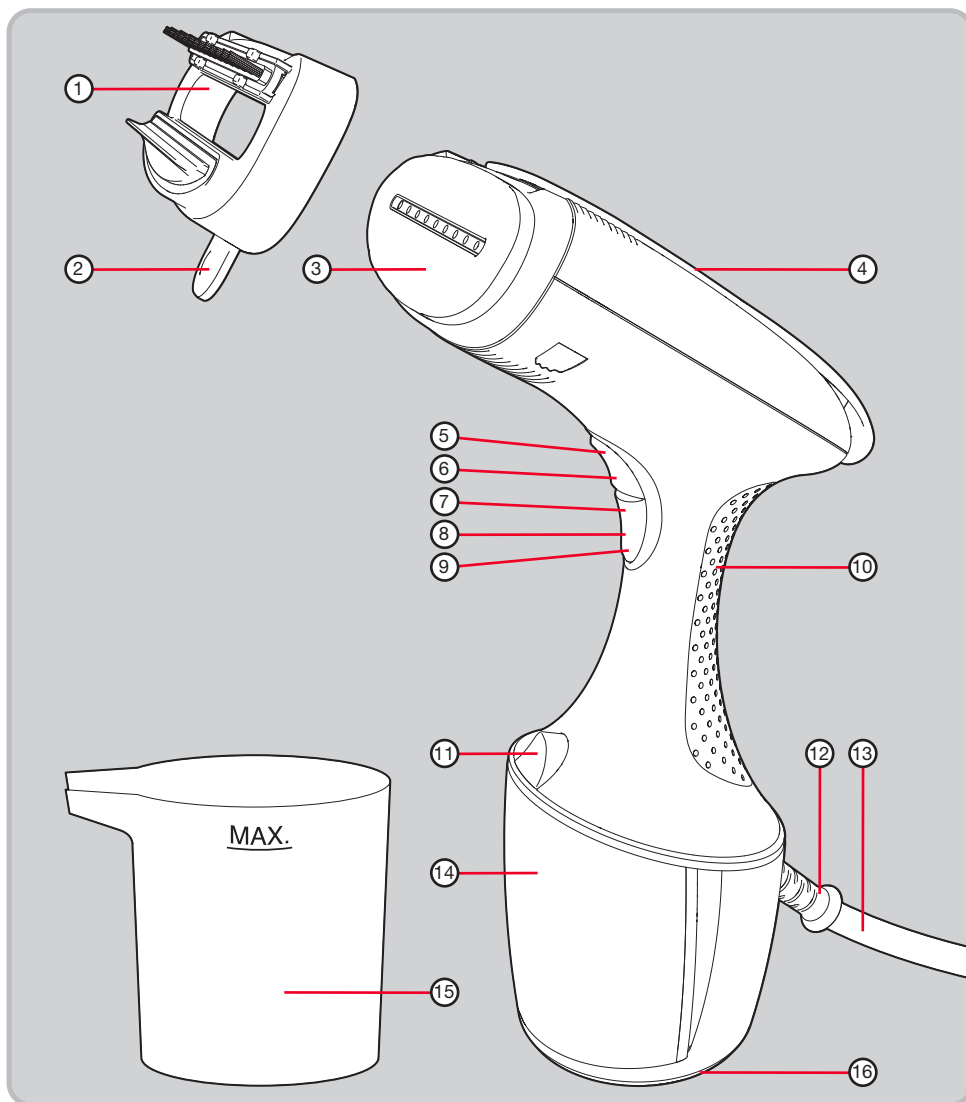

- |  |                                       |                           |
|--|---------------------------------------|---------------------------|
| (1) Brush attachment                     | (6) Steam boost button                | (12) Power cord grommet   |
| (2) Brush attachment removal tab         | (7) Blue steam indicator light        | (13) Power cord           |
| (3) Hotplate                             | (8) Steam button                      | (14) Removable water tank |
| (4) Creaser (with steam hole underneath) | (9) Green temperature indicator light | (15) Filling beaker       |
| (5) Red steam boost indicator light      | (10) Handle                           | (16) Base                 |
|  | (11) Water tank release button        |                           |

## Using the Garment Steamer

### 1) Filling the tank

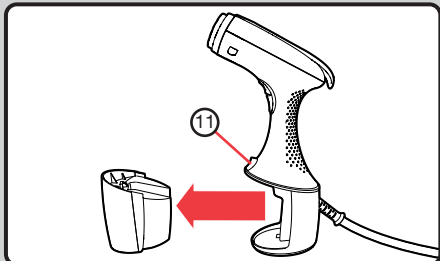

Make sure the Garment Steamer is not plugged in. Press the water tank release button (11) to remove the water tank (14). Lift the bung out of the filling hole and fill the water tank via the filling hole using the filling beaker (15) provided. Then, replace the bung and firmly press the water tank back into position.

**WE RECOMMEND USING DISTILLED, DEIONISED OR DEMINERALISED WATER ONLY.**

**Never use battery topping up fluid or water containing any substances like starch, sugar, fragrant additives or defrosted water from a refrigerator.**

NOTE: Please see point 2 of 'Exclusions' on page 6.

### 2) Switching on

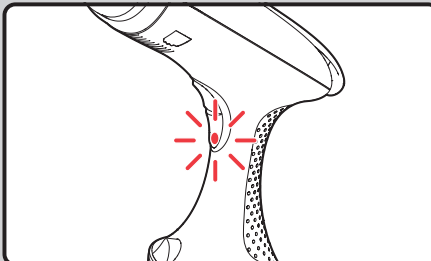

Plug in the Garment Steamer and switch on at the mains.

The green temperature indicator light (9) will flash for approximately 40 seconds until the Garment Steamer has achieved optimal temperature. The appliance is ready to use when the green power light remains constant.

NOTE: Ensure the blue steam indicator light (7) and the red steam boost indicator light (5) are NOT illuminated at this point, otherwise the unit will start steaming automatically once the temperature is reached. Press the steam button (8) or steam boost button (6) to turn them off if necessary.

### 3) Hanging the garment

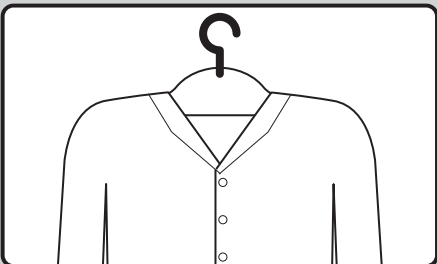

Using a non-metal coat hanger, hang the garment to be steamed.

**CAUTION:** If hanging the garment against a vertical surface such as a door, take care not to damage the surface with steam.

### 4) Brush accessory

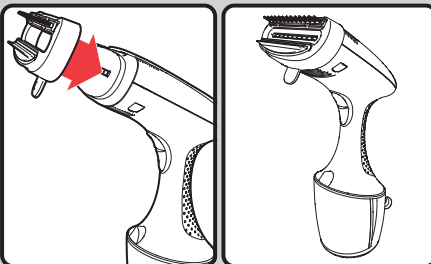

If required, attach the brush attachment (1) to relax the fibres of the garment. Push the attachment onto the hotplate (3) and click it into place.

To remove again, pull the brush attachment removal tab (2).

Brush the garment before steaming.

## Using the Garment Steamer (continued)

### 5) Steaming

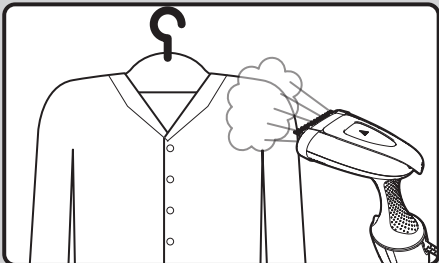

To begin steaming, press and release the steam button (8). The blue steam indicator light (7) will illuminate and steam will be emitted from the hotplate (3). To stop steaming, press and release the steam button again.

Hold the hotplate around 1 inch from the surface of the garment. Pass the Garment Steamer over the garment whilst steaming, you may need to do this a few times to remove more stubborn creases.

**WARNING: Do not direct steam at animals or people. Do not steam clothes that are being worn.**

Without steaming, occasionally brush the garment with the brush accessory to help relax the fibres.

### 6) Steam boost

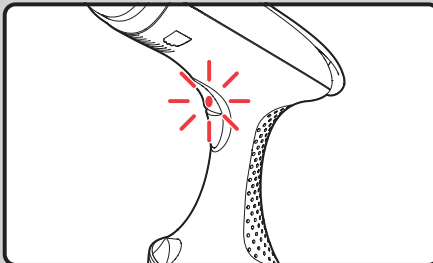

Press the steam boost button (6) for extra steam boost for stubborn creases / heavy fabrics.

To begin the steam boost, press and release the steam boost button. The red steam boost indicator light (5) will illuminate and extra steam will be emitted from the hotplate (3). To stop the steam boost, press and release the steam boost button again.

NOTE: To stop steaming completely, both the blue steam indicator light (7) and the red steam boost indicator light (5) must be off.

## Using the creaser

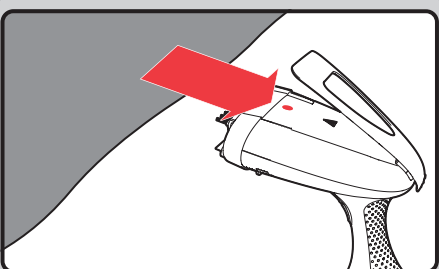

Press down on the rear end of the creaser (4) to lift it up. This reveals a steam hole underneath. With the creaser lifted, slip a folded garment between the creaser and the Garment Steamer and lower the creaser. To begin steaming, press and release the steam button (8). The blue steam indicator light (7) will illuminate and steam will be emitted from the hotplate (3) and the steam hole. Draw the Garment Steamer along the folded edge of the garment to create a crease. To stop steaming, press and release the steam button again.

## Maintenance

### Emptying and storing

When you have finished steaming, unplug and empty all water from your Garment Steamer. When cool, store the Garment Steamer on its base (16) with the power cord (13) wrapped loosely around the handle (10).

NOTE: Please see point 4 of 'Exclusions' on page 8.

### Cleaning the hotplate

#### To clean a stainless steel hotplate

We recommend using a generally available gentle chrome, silver or stainless steel cleaner. Always follow the manufacturer's instructions.

If any man-made fibres fuse to the hotplate (3), pass it over a clean piece of cotton to draw the deposit off the surface.

#### To clean the exterior

Allow the unit to cool and wipe over with a damp cloth and mild detergent, then wipe dry.

